

# CITY OF ELY

501 Mill Street Ely, Nevada 89301  
City Hall (775) 289-2430  
Fax (775) 289-1463

## MEMO

DATE: October 18, 2019  
TO: Mayor Robertson, City Council Members and City Attorney Pyle  
FROM: City Clerk Lee  
RE: Requested research regarding other cities' Council Codes of Conduct

## MESQUITE

**Sec. 2.030 City Council: Discipline of members and other persons; subpoena power.**

1. The City Council may:
  - (a) Provide for the punishment of any member for disorderly conduct committed in its presence.

## HENDERSON

2.40.010 - Purpose. A. The purpose of this chapter is to: 1. Create a city ethics committee that consists of the mayor-pro tem, the city manager, the city attorney and the director of human resources. 2. State ethical standards that are to be applied in public service to the city; 3. To provide a process by which public servants may identify and resolve ethical issues; and 4. To promote public confidence and trust in the integrity of public servants.

2.40.020 - Coverage. A. This chapter applies to all public servants of the city. Public servants include: 1. Elected officials—Mayor and members of city council; 2. Public appointees—All persons appointed by the city council to a city board, commission, or committee that makes decisions, sets policy, or advises or makes recommendations to the city; 3. All city employees; and 4. Contracted employees

2.40.030 - Policy of the city. A. The proper operation of democratic government requires that public servants: 1. Are independent, impartial and responsible to the public; 2. Are agents of the public and hold their position for the benefit of the public; 3. Do not use public office or employment for personal gain; 4. Are bound to discharge faithfully the duties of their public position, regardless of personal considerations, recognizing that the public interest must be their primary concern and shall be loyal to the objectives expressed by the public and the programs developed to attain those objectives; 5. Shall uphold the Constitution of the United States, the Constitution of the State of Nevada and the Charter of the City of Henderson, and carry out impartially the laws of the United States, the State of Nevada and the Henderson Municipal Code, and thus foster respect for all government; 6. Shall not exceed their authority or breach the law or ask others to do so; 7. Shall work in full cooperation with other public servants in the City of Henderson unless prohibited from so doing by law or by the officially recognized confidential nature of their work; and 8. As representatives of the public, their conduct in both official and private affairs should be above reproach.

The City of Ely is an equal opportunity provider and employer.

**SPARKS**

**Chapter 2.01 - CODE OF ETHICS**

**Section 2.01.010 - Purpose and intent.**

A.

The city council finds and declares as follows:

1.

The people have a right to expect from their elected and appointed representatives at all levels of government assurances of the utmost in integrity, honesty and fairness in their dealings;

2.

The people further have a right to be assured to the fullest extent possible that the private financial dealings of their governmental representatives, and of candidates of those offices, present no conflict of interest between the public trust and private gain; and

3.

The representative form of government is founded upon a belief that those entrusted with the offices of government have nothing to fear from full public disclosure of their business holdings as they pertain to the business before the Sparks city council.

B.

The city council intends to sustain, to the extent necessary, public confidence in government at all levels, by assuring the people of the impartiality and honesty of their officials in all governmental transactions and decisions.

C.

The provisions of this chapter are to be construed liberally, to the end that the public interests are fully protected.

(Ord. 1440 § 1 (part), 1984.)

**Sparks City Charter**

Sec. 2.020 City Council: Discipline of members, other persons; subpoena power.

1. The City Council may:

(a) Provide, by resolution or ordinance, for the discipline of any elected or appointed officer of the City for unethical conduct.

**FALLON**

**2.04.080 - Punishment or expulsion of city council members.**

The city council may punish its members for disorderly conduct, and, with the concurrence of two-thirds of the members of the city council, may expel a member for cause.

(Ord. No. 743, 10-15-2013)

The City of Ely is an equal opportunity provider and employer.

## ELKO

### **1-6-16: DISTURBING MEETINGS; PENALTIES:**

D. By a majority vote of the council, any council member maybe punished or reprimanded for disorderly conduct during a meeting, and, with the concurrence of four (4) of the council members, may expel a member from a meeting for violations of any provision of this section. (Ord. 254, 9-19-1977)

## WEST WENDOVER

❖ Research done by Mayor Robertson:

Some other info and research from the West Wendover City Manager.

----- Forwarded message -----

From: Chris Melville <[cmelville@westwendovercity.com](mailto:cmelville@westwendovercity.com)>

Date: Thu, Oct 17, 2019 at 10:41 AM

Subject: Re: Council Code of Conduct

To: Ely Mayor <[mayor@elycity.com](mailto:mayor@elycity.com)>

Mayor Robertson.

We basically have a three prong approach to conduct related to elected officials.

First, we do rely on the basic principles as laid out in statute and as recommended by the Nevada Ethics Commission. We coordinate regularly with the Commission Director Yvonne Nevarez-Goodson who makes herself and/or staff available to provide general training when we request it for our elected and appointed officers. This in addition to what they can obtain through League of Cities conferences/meetings.

Second, the elected officials do operate at their Council Meetings under adopted Decorum Rules, Procedures and Conduct. These rules apply to the elected officials, staff as well as the public. Here is a link to our rules: <http://www.westwendovercity.com/home/showdocument?id=408>

Thirdly, under our personnel policies as adopted, our elected officials are also expected to adhere to certain provisions that are applicable to them including policies on chain of command, workplace conduct, code of ethical standards, political activity, etc. Here is a link to where you can access our adopted personnel policies: <https://www.westwendovercity.com/services/resources-and-forms-online/-folder-216>



# City of Ely Organization Chart

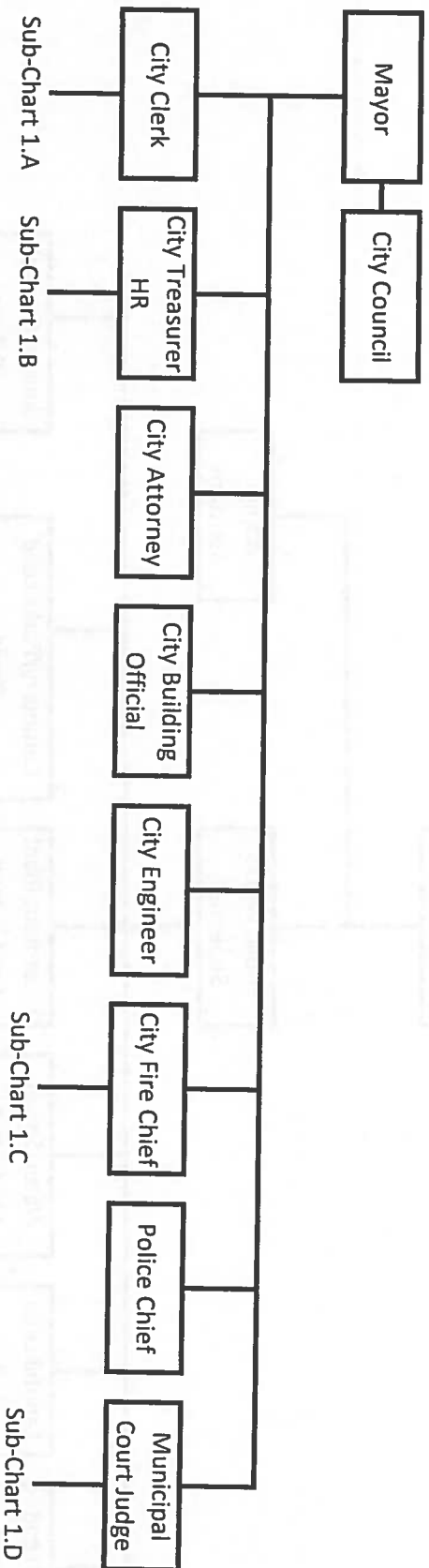

- The purpose of this chart is to offer members of the City organization guidance on how and from whom direction shall be given in regards to each employee's responsibilities.
- The organizational chart is also intended to provide employees direction on to whom they may appeal with complaints, questions or other issues that may arise in the course of fulfilling their duties.
- The intent of the organization chart being that employees shall seek direction and redress from their direct supervisors (going up the chain of command) and that the Mayor and members of the City Council provide direction and seek information from those under their direct supervision (i.e. appointed officials/department heads).
- Every position within the City of Ely is not listed as part of this document. Those positions not listed are understood to be under the supervision of the next highest position listed on this organizational chart or sub chart in the department in which they serve.
- This chart (including sub charts) may be changed or amended as departments are rearranged, added or removed.

Sub-Chart 1.A

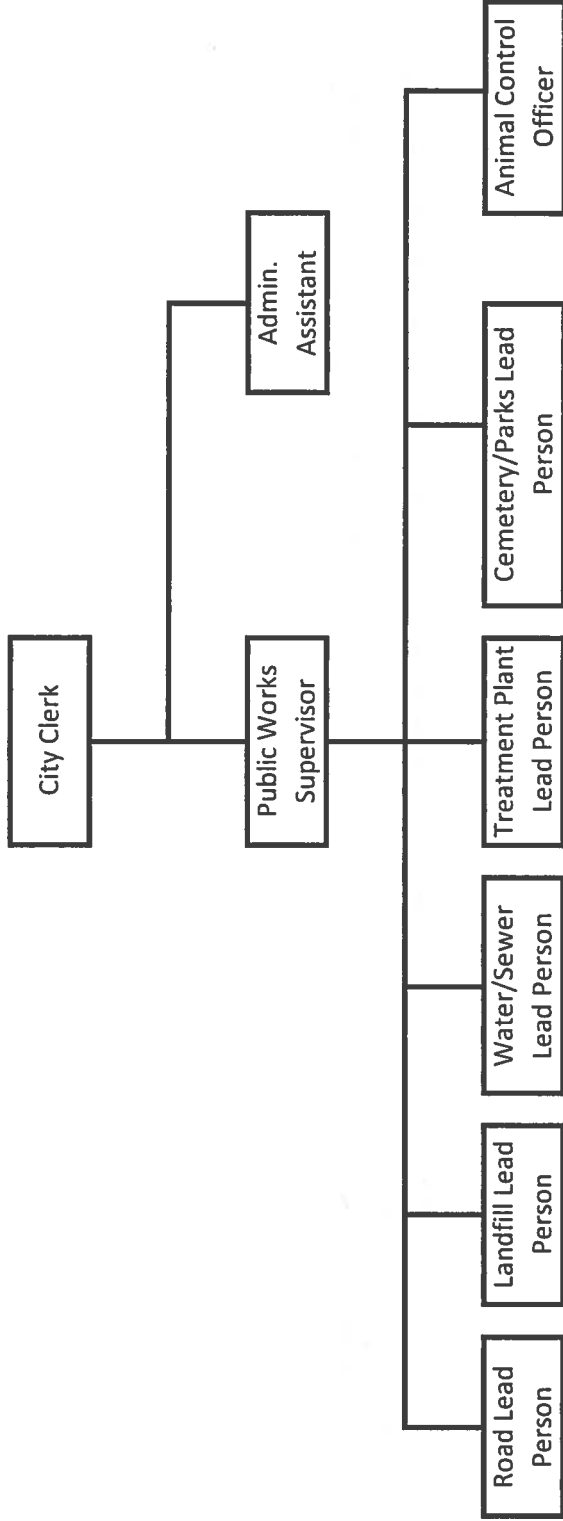

Sub-Chart 1.B

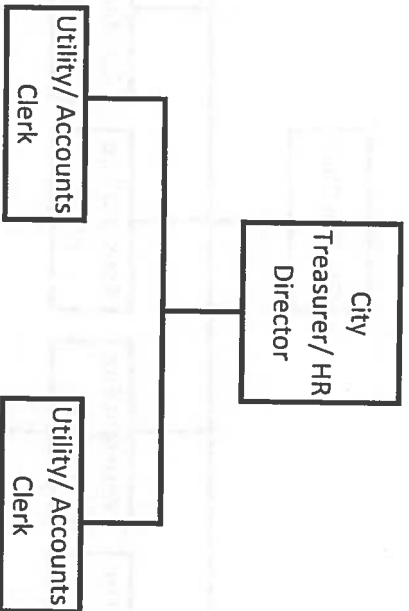

- The City Treasurer shall also serve as the head of Human Resources for the City of Ely.

- As such all employees of the City may approach at any time their direct supervisor or the City Treasurer in regards to a human resource matter.

**Sub-Chart 1.C**

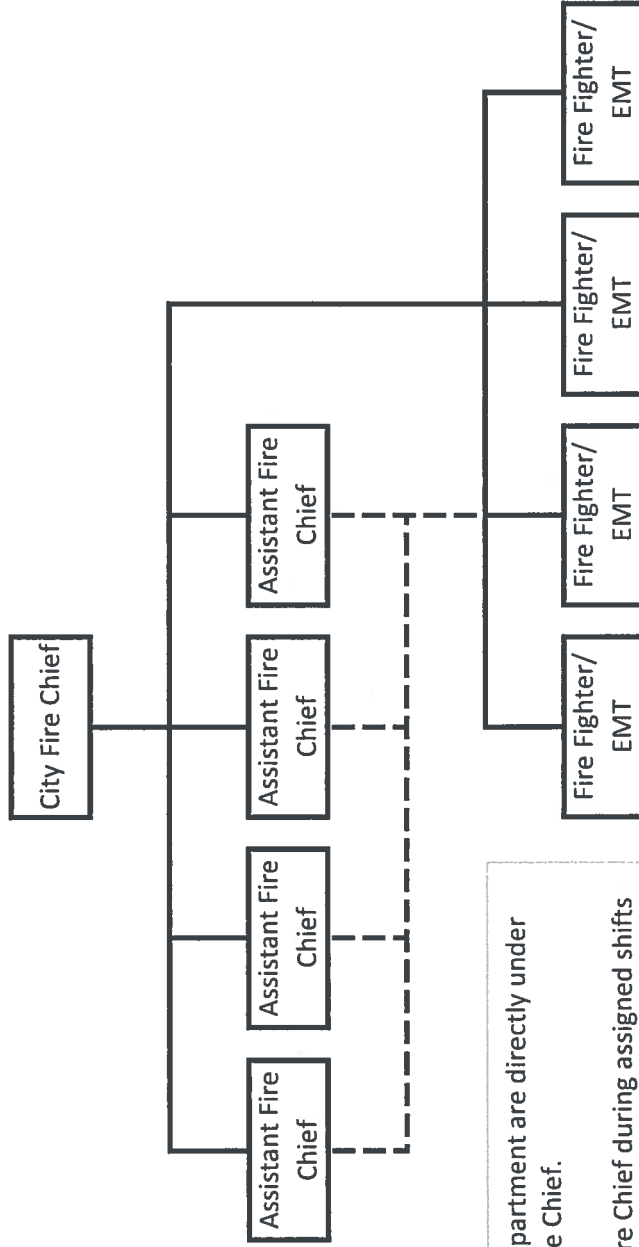

- All employees of the Fire Department are directly under the supervision of the City Fire Chief.

- In the absence of the City Fire Chief during assigned shifts and responding to calls employees on duty are under the direction of the Assistant Fire Chief who is also on duty or also responding to the call.



Sub-Chart 1.D

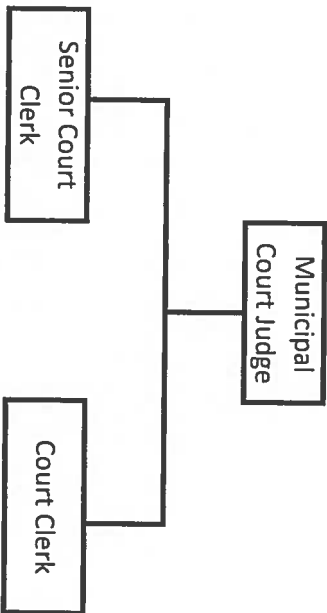



**Summary:** An ordinance amending Chapter 5 of Title 1 of the City Code of the City of Ely requiring the City Council to create a code of conduct for its members; proscribing that violation of the Code of Conduct constitutes cause within the meaning of NRS 266.240; eliminating appointed department heads; creating a protocol for liaison appointments; proscribing that no city official may be appointed to a department if such appointment implicates a conflict of interest and; adding a severability clause.

**TITLE:**

**PROPOSED ORDINANCE AMENDING CHAPTER 5 OF TITLE 1 OF THE CITY CODE OF THE CITY OF ELY REQUIRING THE CITY COUNCIL TO CREATE A CODE OF CONDUCT FOR ITS MEMBERS; PROSCRIBING THAT VIOLATION OF THE CODE OF CONDUCT CONSTITUTES CAUSE WITHIN THE MEANING OF NRS 266.240; ELIMINATING APPOINTED DEPARTMENT HEADS; CREATING A PROTOCOL FOR LIAISON APPOINTMENTS; PROSCRIBING THAT NO CITY OFFICIAL MAY BE APPOINTED TO A DEPARTMENT IF SUCH APPOINTMENT IMPLICATES A CONFLICT OF INTEREST AND; ADDING A SEVERABILITY CLAUSE.**

**Whereas,** NRS 266.240 provides that the City Council shall determine its own rules of procedure, may punish its members for disorderly conduct, and, with the concurrence of two-thirds of the members of the city council, may expel a member for cause;

**Whereas,** Chapter 266 of the Nevada Revised Statutes provides that the Mayor is the chief executive of the City of Ely charged with supervising the affairs of the the City, enforcing the rules of the City Council, and preserving order and decorum among the members of the City Council;

**Therefore,** the City Council of the City of Ely, State of Nevada, does AMEND and otherwise ordain that the sections of Chapter 5 of Title 1 of the City Code of the City of Ely specified below shall read as follows:

**1-5-6: DEPARTMENTS OF CITY COUNCIL:**

A. Designation: The city council is hereby segregated into five (5) departments to be known as the public safety department, health and sanitation department, parks and recreation department, street department, water & sewer department and administration department. (Prior Code § 2-27)

~~B. Department Heads~~ Liaison Appointments: The mayor shall be responsible for the administration department of the City. The mayor shall further appoint from the council membership ~~departmental heads~~ liaisons for the remaining ~~four (4)~~ five (5) departments. (Prior Code § 2-27A)

C. Scope And Jurisdiction: The scope and jurisdiction of such departments shall be the following:

1. Administration Department: The administration department shall include the city clerk's office, city treasurer/human resource office and city Municipal court, and parking meters.

2. Public Safety Department: The public safety department shall include the police, ~~and fire department~~ and building departments.

3. Health And Sanitation Department: The health and sanitation department shall include the landfill and sewage treatment facility.

4. Street Department: The street department shall include all city streets, streetlights and storm drains.

5. Parks And Recreation Department: The parks and recreation department shall include the city parks and the city cemetery. (Prior Code § 2-27B)

6. Water and Sewer Department. The water and sewer department shall include all city water and sewer infrastructure not within the scope and jurisdiction of the above departments.

~~D. Operating Heads~~ Role of Appointed Liaisons: Liaison appointments ~~The present operating heads of the various departments are not supervisory in nature. Instead, the primary function of a Council liaison is to be a two-way communication vehicle between the Council and the department to which he or she is appointed. Council liaisons must be in touch with their appointed department to communicate what is going on with the City of Ely as a whole and how it affects the department, and to give direction, guidance, and support to the department. Council liaisons must provide reports to the Council regarding the department from time-to-time. shall be placed under the immediate supervision of the councilmen selected as department heads as provided for under subsection A of this section, subject to the approval of the mayor.~~ (Prior Code § 2-27C)

E. Conflicts of Interest: No city official, whether councilmember or the mayor, may serve as liaison to any department which employs the city official or employs any person or entity to which the city official owes a commitment in a private capacity. Likewise, no city official may serve as liaison to any department whose operations confer a pecuniary benefit upon the city official or any person or entity to which the city official owes a commitment in a private capacity.

**1-5-7: CONDUCT OF THE CITY COUNCIL:**

The City Council shall adopt and be bound by a code of conduct for its members. Violation of the Code of Conduct shall constitute cause for removal within the meaning of NRS 266.240.

**1-5-87: SALARIES OF ELECTED OFFICIALS:**

A. Mayor: The salary of the mayor shall be set at six hundred dollars (\$600.00) per month.

B. Councilmen: The salaries of each respective city council member shall be set at five hundred dollars (\$500.00) per month. (Ord. 518, 6-12-1997)

**1-5-9: SEVERABILITY:**

If any provisions of this Ordinance are held invalid, such invalidity shall not affect other provisions and each provision is hereby declared to be severable.

This Ordinance shall take effect from and after passage, approval, and publication.

PROPOSED on the \_\_\_\_ day of \_\_\_\_\_, 2019.

PROPOSED by \_\_\_\_\_.

PASSED on the \_\_\_\_ day of \_\_\_\_\_, 2019.

Votes:

Yay: \_\_\_\_\_

\_\_\_\_\_

\_\_\_\_\_

\_\_\_\_\_

\_\_\_\_\_

Nay: \_\_\_\_\_

\_\_\_\_\_

\_\_\_\_\_

\_\_\_\_\_

Absent: \_\_\_\_\_

\_\_\_\_\_

\_\_\_\_\_

\_\_\_\_\_

\_\_\_\_\_

\_\_\_\_\_  
MAYOR

ATTEST:

\_\_\_\_\_  
CITY CLERK